







FITTING INSTRUCTIONS

(AIRBAG OPERATING HEIGHT & MAXIMUM PRESSURE)

RR4730



-  This air suspension system is designed to assist the original vehicle manufacturer's suspension – it is not meant to carry the entire rated load. We do not recommend that leaves be removed, or other changes be made from the OEM suspension unless an applicable commercially available suspension kit is fitted.
-  The kit is designed to suit a standard vehicle configuration – modifications to the vehicle outside the kit design parameters may adversely affect fitment and operation such as:
 - Height changes outside any noted in the kit specification.
 - Larger dampers (Shock Absorbers)
 - Wheel and tyre changes
 - Exhaust changes.
-  If your vehicle is fitted with a brake proportioning valve or stability control system it is important to ensure this is maintained and adjusted according to the vehicle manufacturer's instructions.
-  It is recommended that only a properly qualified person installs the product and carries out maintenance. If you are not qualified and attempt to carry out such work ensure that all safety equipment is used and safety standards are met.
-  Ensure that you have read the full Product Manual before attempting to fit the product.
-  Ensure the Product Manual is kept with the vehicle and that any vehicle owner and/or operator is fully advised on the system and its operation before attempting to drive or operate it.



SEE OTHER WARNINGS AND IMPORTANT INFORMATION IN THE PRODUCT MANUAL

LHS = LEFT SIDE OF THE VEHICLE WHEN FACING FORWARD

STEP 1 - PREPARE THE VEHICLE

In order to fit this kit, the u-bolts may need to be loosened or removed. Ensure this operation is carried out according to the vehicle manufacturers' instructions.

STEP 2 - AIRLINE TUBING & FITTINGS - GENERAL NOTES

CUTTING

Only cut the airline tubing with a sharp blade making the cut as square as possible.

Always trim the tubing before re-inserting into the fitting.

-  If you use a sharp utility knife or razor blade great care must be taken in all cases not to cut yourself during this operation.

CONNECTING & REMOVING

To connect:

Push the freshly trimmed tubing into the fitting as far as possible.

To remove:

First release the air pressure from the system. To withdraw the tubing, push and hold the collar on the fitting away from the tube and pull out the tubing.

Hint In confined spaces an open-ended spanner can be used to evenly depress the collar and remove the airline tubing.

CUT TUBING SQUARE WITH SHARP BLADE OR CUTTER

DO NOT USE PLIERS, CUTTERS OR PIPE CUTTERS

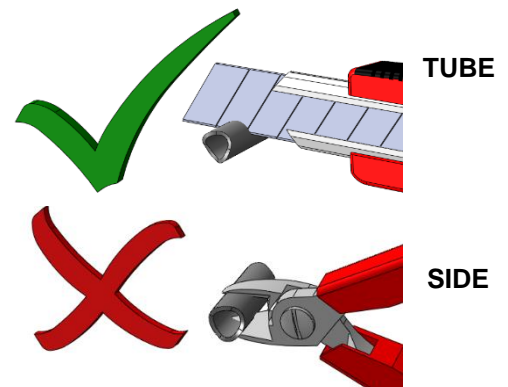

STEP 3 - POSITION YOUR INFLATION VALVES

Select a convenient location for the air inflation valves such as the bumper or the body of the vehicle. It must be protected from road damage and be accessible for air inflation equipment.

Drill a 5/16" hole and install the air inflation valve using two 5/16" stainless steel washers as supports where required.

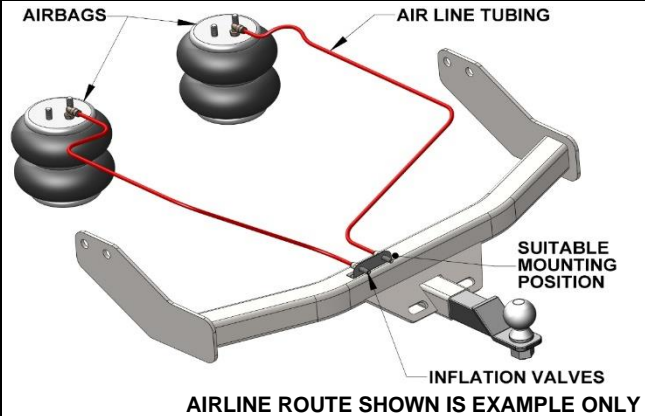
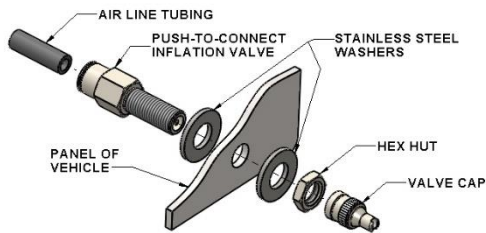

STEP 4 - PREPARE THE AIR LINE TUBING

Decide on a suitable route for the air line from the airbag to the inflation valve location to avoid direct heat from engine, exhaust pipe, and away from sharp edges.

Uncoil the air line tubing being careful not to fold or kink it and cut to length to suit the chosen route. Next cut a suitable length of protector tube and feed over the air line tubing. (See opposite)

DO NOT CONNECT OR SECURE THE AIR LINE AT THIS POINT



STEP 5 - REMOVE BUMP STOP

Loosen the rear axle u-bolts enough to remove the bump stop from the leaf pack.

NOTE- The u-bolts are re used to fit the lower bracket.

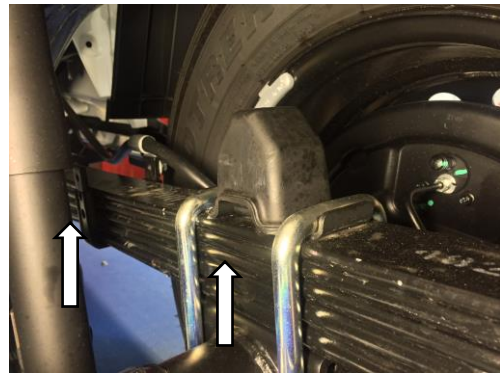

STEP 6 - FIT THE LOWER BRACKET TO THE VEHICLE

Place the u-bolts over the lower bracket.

Ensure that the lower bracket is orientated correctly. The larger hole in the bracket should be facing inboard of the vehicle.

Tighten as per manufacturers recommended torque settings.

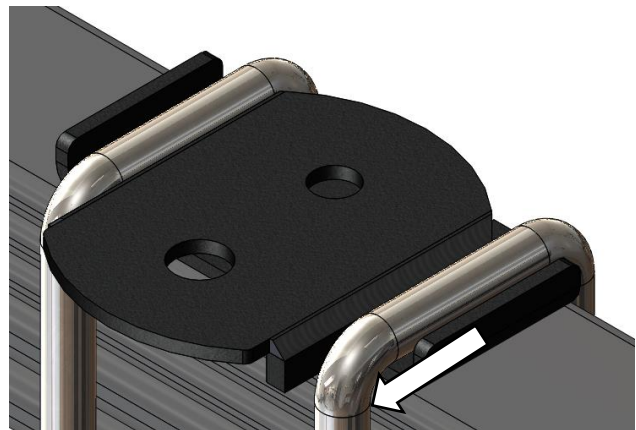

LARGE HOLE INBOARD

STEP 7 - ASSEMBLE THE UPPER BRACKET TO THE AIRBAG

Fasten the upper bracket to the airbag using the supplied 3/8" x 3/4" countersunk bolt.

The same upper bracket part is used for the Left and Right sides. Tighten the countersunk bolt ensuring the 4x holes are positioned outboard with the airbag inlet positioned inboard as shown.

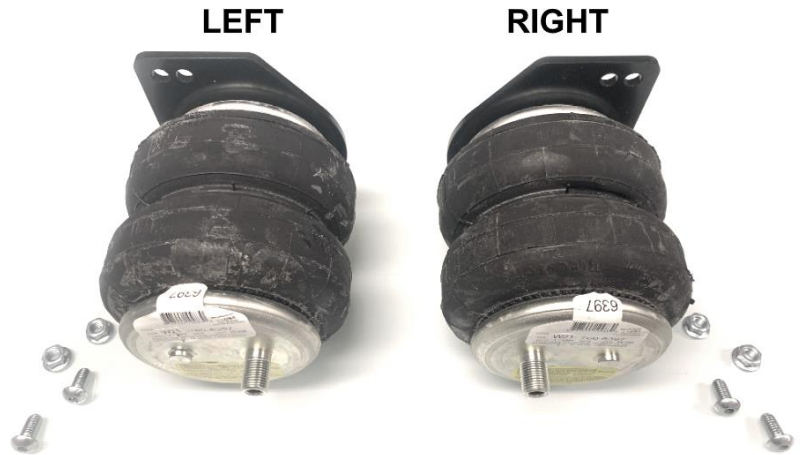

STEP 8 - FIT THE AIRBAG ASSEMBLY TO VEHICLE

Fit the airbag with upper bracket to the vehicle, aligning the flat outer edge of the upper bracket to the outer edge of the vehicle bump stop striker. The forward inner hole and the rearward outer hole will align with the vehicle holes in the bump stop striker.

Use the supplied 3/8" x 3/4" dome head bolts and the cone lock nuts to mount through the bump stop striker holes.

IMPORTANT – ensure the dome heads of the bolts are positioned on the underside of the bracket to provide a smooth surface for airbag compression.

LEFT



LEFT REARWARD



LEFT FORWARD



STEP 9 - FIT THE AIRBAG ASSEMBLY TO THE LOWER BRACKET

Fit the airbag with a lower B2326 crash plate and then to the lower bracket by feeding the long 'combo stud' into the inboard hole on the bracket.

Ensure that the small stud is also located in the lower bracket hole.

Secure the airbag in place with the 5/8" nut and star washer supplied.

Once the lower bracket is secured to the airbag, tighten the 3/8" x 3/4" Flange Bolt on the top of the airbag to fully secure it to the upper bracket.

A 9/16" spanner will be needed to reach the flange bolt.



STEP 10 - FIT AIR FITTING TO THE AIRBAG

Fit the supplied 1/4" x 1/8" Elbow air fitting in the air entrance hole on the top plate (stud end) of the airbag and tighten until the fitting is snug.

No additional thread sealant needed. If these fittings are re-fitted many times, they will degrade their sealing ability.

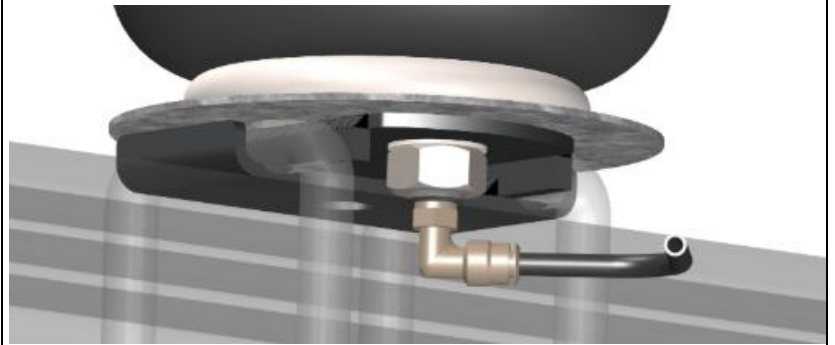

STEP 11 - CONNECT AIRLINE TUBING

Connect the airline to the air fitting then route the airline tubing along the axle with hard brake lines, then up the flexible brake line and up over tray mounts to dodge the spare tyre. Connect to the air inflation valves. Secure with supplied nylon ties.



STEP 12 - INSTALL OPPOSITE SIDE

Repeat Steps 5-11 for the opposite side of the vehicle.

STEP 13 - LEAK TEST

INFLATE the airbag to the maximum allowed pressure (see Airbag Operating Height & Maximum Pressure attached) and check for leaks at the connections using soapy water spray. We recommend a soapy water spray solution of 25% soap to 75% water.

DEFLATE airbag. If no leaks, continue. If leak detected, check and tighten the airbag fittings (if required), remove the airline tubing, re-cut and re-test.

STEP 14 - FITMENT COMPLETION

Reattach all suspension components removed earlier and return the vehicle to driving position. Ensure this operation is carried out according to the vehicle manufacturer's instructions.

STEP 15 - AIRBAG HEIGHT AND ALIGNMENT

The airbag must be checked for the correct installed height, vertical alignment and clearances with the vehicle levelled out.

INFLATE the airbags until a level vehicle height is reached and measure the bag height between the mounting plates.

The AB0120-1A airbag in this kit requires a height of 6.0" to 7.0" to be maintained under all loads.

It is important to ensure that the airbag does not make contact with any other components in all load and height conditions.

If the centreline of the airbag end plates are misaligned in any direction more than the amount shown to the right, please contact Airbag Man on 1800 247 224 for further technical support.

Please note: Misalignment and angled installation at ride height is often required to ensure correct alignment through the suspension travel.

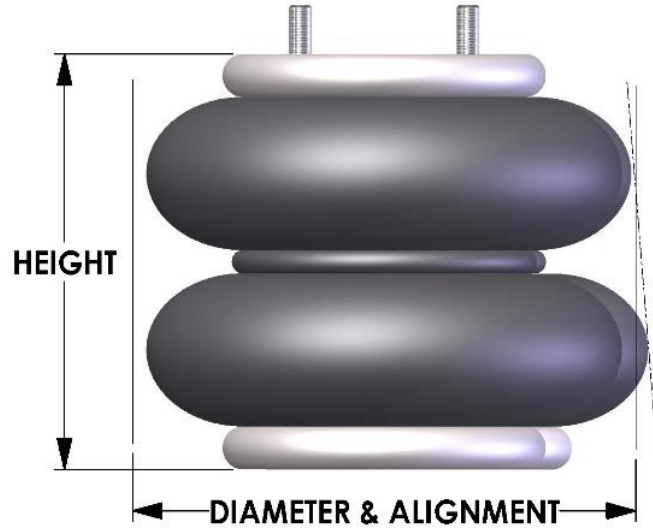

Standard airbag misalignment tolerance allowed is 20mm

STEP 16 - TO FINISH

Ensure the **WARNING** label is fixed in a prominent position in sight of the vehicle operator.

Ensure the Product Information Wallet is given to the vehicle owner/operator.

Ensure the vehicle owner/operator fully understands how to use the product.

All fixings should be checked for tightness after the first laden run and thereafter as per the original manufacturer's recommendations.

AIRBAG OPERATING HEIGHT & MAXIMUM PRESSURE

See operating instructions section for proper use and maintain the specific height below:

OPERATING HEIGHT

The AB0120-1A airbag in this kit requires a height of 6.0" to 7.0" under all loads. Adjust and retain pressure up to the stated maximum to maintain the airbag operating height. Failure to do so may result in product or vehicle damage not covered under warranty.

MAXIMUM PRESSURE

50 PSI (3.5 bar)

**IF MORE PRESSURE IS REQUIRED TO MAINTAIN THE OPERATING HEIGHT CALL
AIRBAG MAN ON 1800 247 224 FOR FURTHER TECHNICAL ADVICE**



FREECALL 1800 247 224



- ⚠** Incorrect use of this air suspension product can result in damage to the airbag, associated parts and/or the vehicle, which is not covered under warranty.
- ⚠** Ensure the airbags are maintained at the stated ride height at all times and maintain the minimum pressure required and never exceed the maximum.